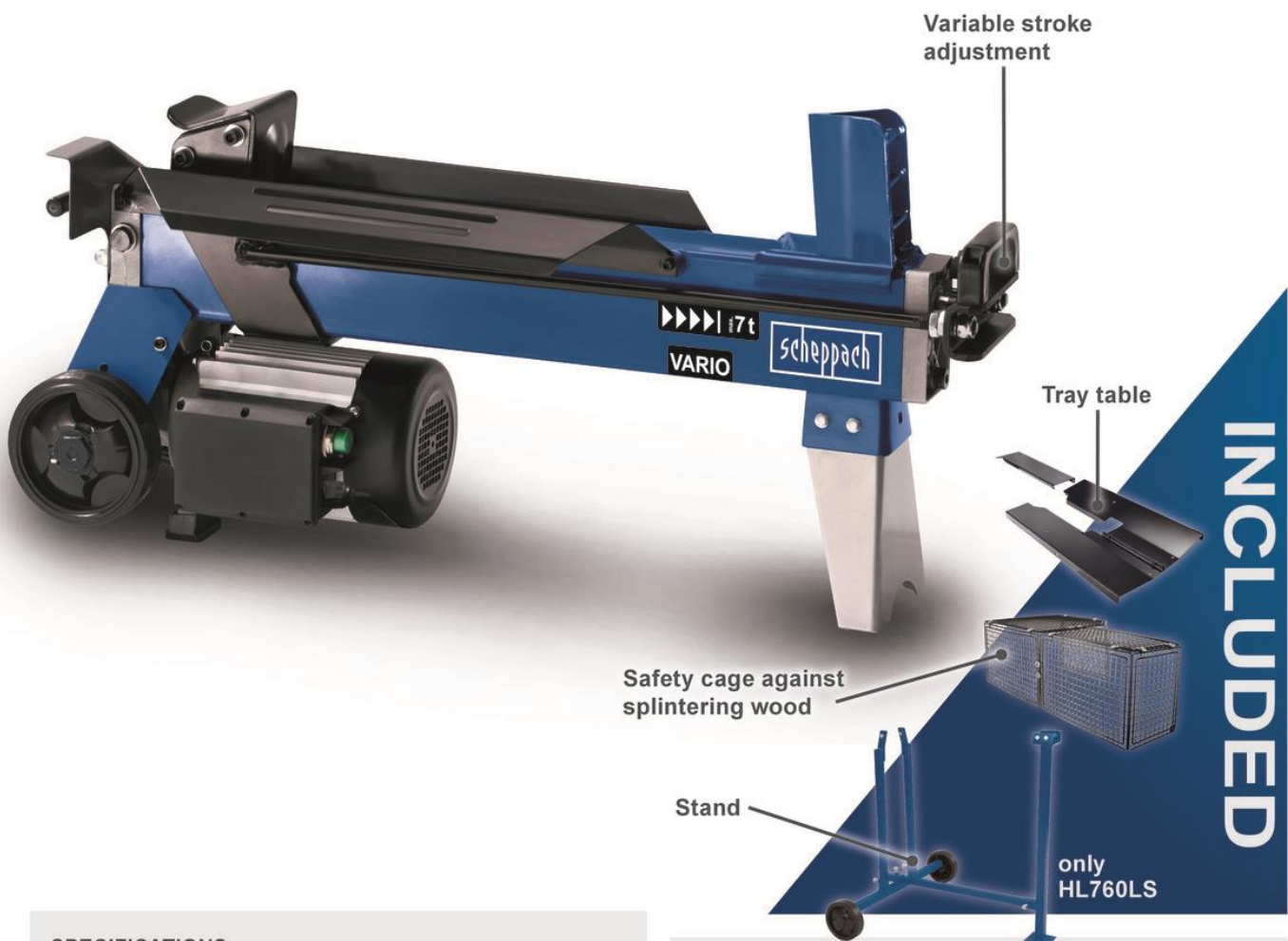

7 T SPLITTER

- Splits stored and fresh wood effortlessly
- Splitting force: **7 tonnes**
- **Log splitter capacity maximum length 52 cm, up to 25 cm diameter**
- Hydraulic cylinder with automatic return
- Torsion-resistant, powder-coated steel structure
- Sturdy splitting blade
- Powerful **motor of 2200 W**
- Freely-adjustable splitting stroke
- **Optimised safety thanks to two-handed operation**
- **Low maintenance, small footprint**
- Safety cover around the splitting area
- Tray table for logs
- **Including machine stand (HL760LS)**

**SPECIFICATIONS**

Dimensions L x W x H	1160 x 425 x 610 mm (HL760L) 1160 x 725 x 1350 mm (HL760LS)
Splitting power max.	7 t
Wood Ø min. – max.	50 – 250 mm
Wood length min. – max.	200 – 520 mm
Speed forward	3,08 cm/s
Speed backward	5,29 cm/s
Motor	220 – 240 V~ / 50 Hz
Input	2200 W

LOGISTICAL DATA

	HL760LS	HL760L
Weight net / gross	59 / 64 kg	59 / 63 kg
Packaging dimensions	950 x 325 x 510 mm	
Article number	5905211934	5905211903
Barcode	4046664120698	4046664121787
20 Container	168 pcs	168 pcs
40 Container	344 pcs	344 pcs
40 HQ Container	430 pcs	430 pcs